

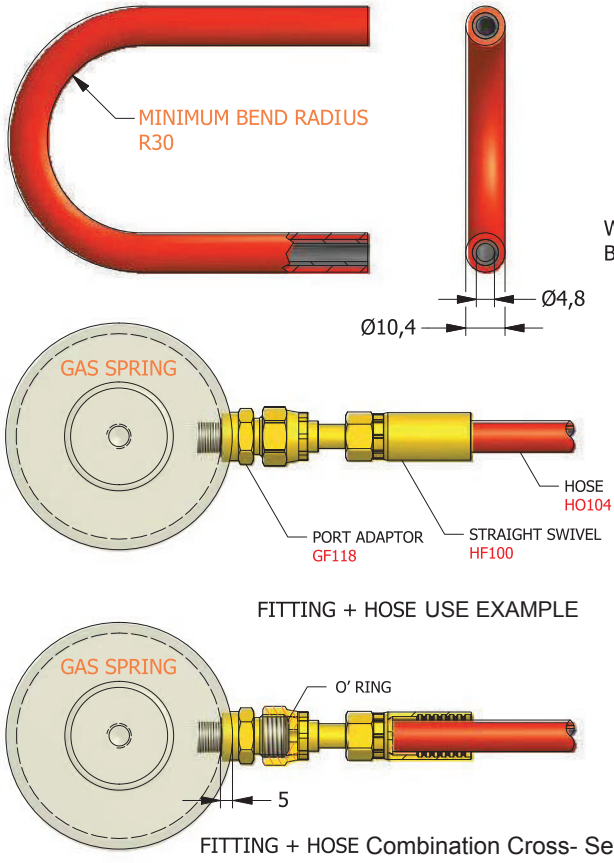

HOSE HO104



GF FITTING

GF FITTING is the most common fitting system by using HOSE HO104. It can be installed in fitting system by variety combinations.

WORKING PRESSURE 200bar  
BURST PRESSURE 700bar

